

STEICO Sarking and Sheathing boards Installation instructions

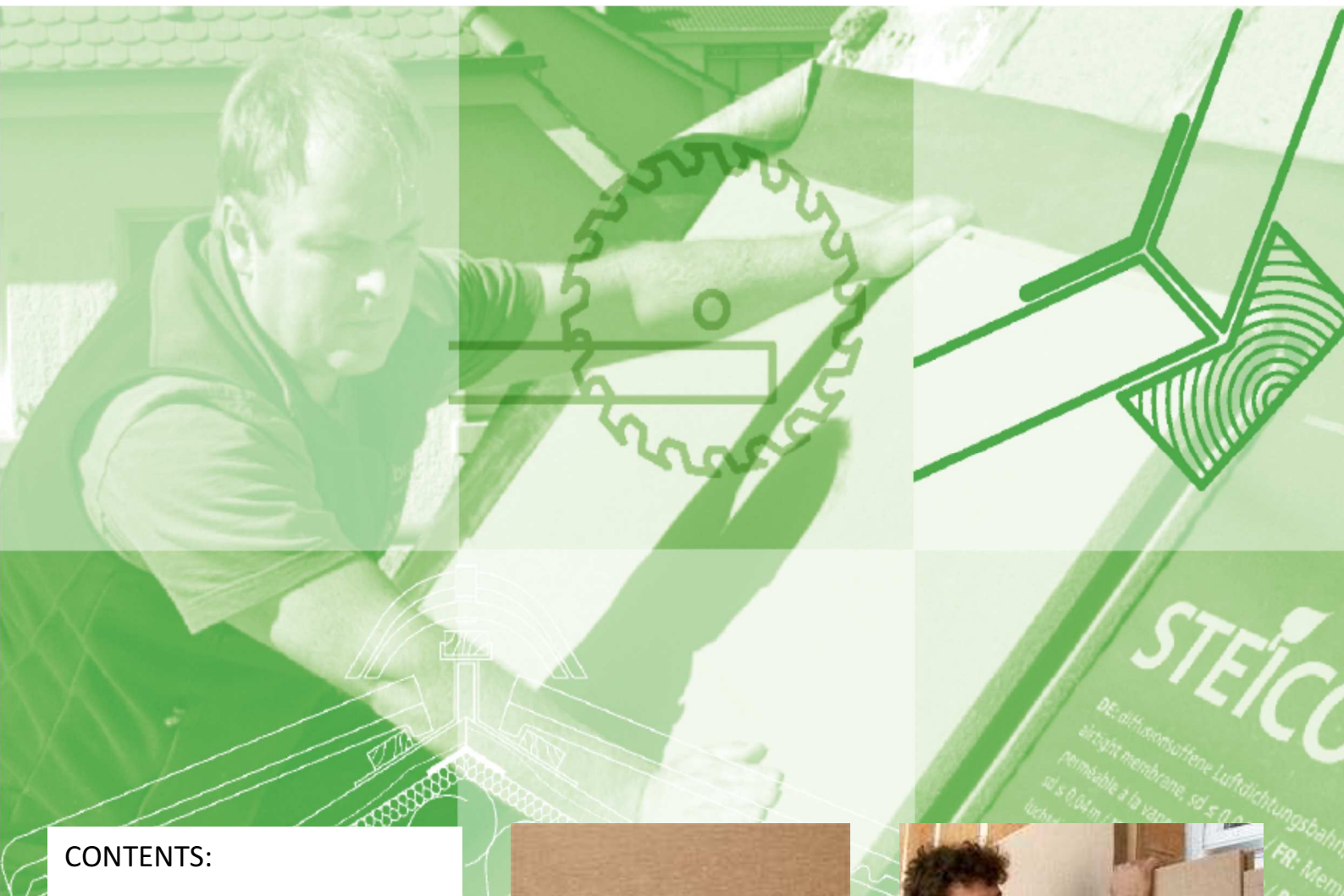

CONTENTS:

General Information	p.2
Installation Instructions	p.4
Fixing Method	p.6
Generic Details	p.11



General Information

STEICO manufactures a wide range of hydrophobic wood fibre insulation boards which can be used for external sarking and sheathing.

The products *STEICOuniversal* and *STEICOspecial* are produced using a wet process system, and *STEICOuniversal dry* and *STEICOspecial dry* using a dry process. Further information is available via the individual product data sheets.

- STEICO sarking and sheathing boards are fully T&G profiled to all edges. Additional taping and sealing of the boards used in Wall applications or Roof applications with a minimum pitch of 18° is not required.
- STEICO*universal* / *universal dry* and *special dry* are fully hydrophobic. Additional treatment of square cut board edges is therefore not required. They can also be reversed during installation in order to reduce on site wastage. STEICO*special* wet process board cannot be reversed as only the top layer is fully hydrophobic.

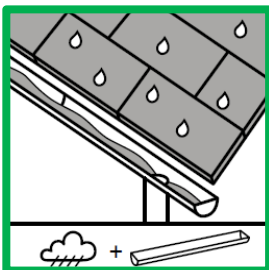
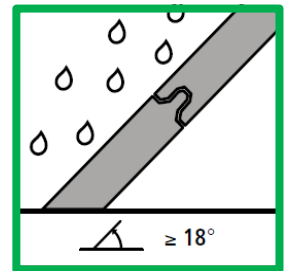

- The external face of the boards should remain unobstructed in order to allow the natural passage of water vapour. STEICO wood fibre boards should be protected from the long term effects of weathering. Boards that have been subjected to excessive moisture levels should be allowed to dry out via internal ventilation before the structure is closed.
- Due to production methods the top face of Wood fibre board is often covered with a fine, invisible layer of sugars, lignin and fibres that can be dissolved by running water, and hence lead to staining of adjoining building components (ie: Windows, Rendering etc.). A controlled removal of rain water should therefore be undertaken during the construction process.
- The boards are printed with the external surface clearly marked. Generally the sanded face should point to the inside.

- STEICO wood fibre boards can be utilised as a temporary weather protection for up to 4 weeks. This can be increased up to 12 weeks if the board underside is exposed and any possible moisture is allowed to evaporate out.
- High snow loading should be avoided.

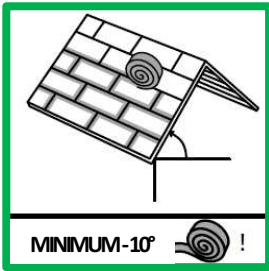
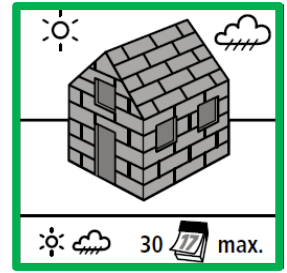

- The minimum allowable pitch is 18°. Pitches as low as 10° are allowed but one of the additional measures as detailed below is required:
 - **Taping and sealing the joists :**
Ensure STEICO boards are dust free and dry before application. The taped areas should be treated with an appropriate sealer recommended by the tape manufacturer.
 - **Sealing with STEICO*multi fill* :**
A continuous 5mm diameter bead should be applied to the back third of the tongue profile. STEICO*multi fill* should squeeze out of the T&G profile once the boards are pushed together and this excess material should be sanded off once dry. One tube of STEICO*multi fill* should allow approx. 8 linear meters of bead.
 - **Using an external vapour open membrane eg. STEICO *multi UDB* :**
At all connections and joints the membrane should be sealed with a tape recommended by the membrane manufacturer.

- STEICO wood fibre boards are water vapour open products. Condensation forming on the inside of the board during construction can hinder this process. Increased humidity in the building due to plaster, screeds or paints should be removed with suitable ventilation. Additional measures such as dehumidifiers are recommended. Internal vapour control layers or vapour barriers should be fitted and sealed before any such work is undertaken. The vapour diffusion factor of humidity variable membranes reduces with high humidity and this should be carefully considered with increased internal humidity (internal plaster, wet screeds) during the winter months.

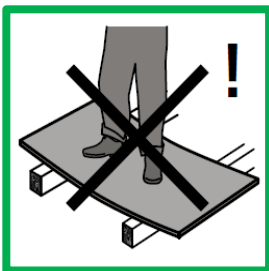
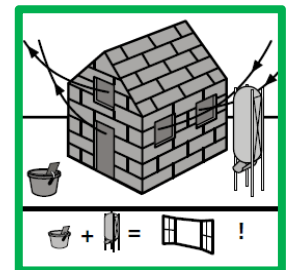

- STEICO wood fibre boards can be walked on directly above a rafter or joist support, however they cannot be used as the primary walking surface. It is recommended to install the counter batten and tile batten at the same time as the STEICO board in order to increase the available support areas. Additional fall protection (Man Safe systems) should be used in line with national guidelines.
- Detailing of the Gable and Eaves structure should be considered before starting with the installation of STEICO wood fibre boards. If the detailing requires a square end cut of the boards then the project Architect should ensure a robust external water proofing detail with a suitable sealing and taping system.

Installation Instructions

- The fitting of the boards starts from the bottom left hand corner. The tongue points upwards and the printing on the board details which side is internal or external. The offcut from the first row should be used to start the beginning of the second row. Vertical joists should be staggered on each row. STEICOuniversal with a thickness of 22mm should be staggered by a minimum of 600mm and all other thicknesses by a minimum of 250mm.
- The boards can be temporarily nailed with a large flat head nail with the long term fix provided via an appropriate counter batten. A nail tight tape beneath the batten is not required. Additional fixing details are provided in the tables on pages 6 – 9.

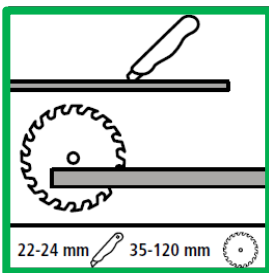
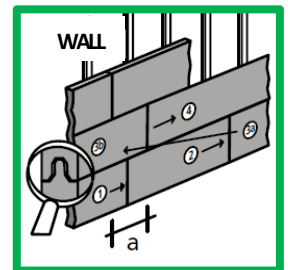
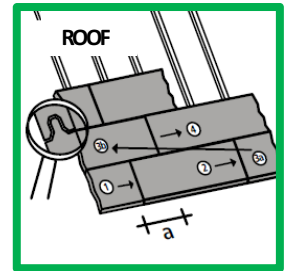

- The appropriate cutting tool should be used based on the thickness of the material. When connecting to other parts of a building a clean, parallel cut with minimum gap should be ensured. For all thick wood fibre boards we would recommend the use of a Protool, Type Uniers SSP 200EB. This can cut insulations up to 200mm thick.
- When using air injected insulation such as STEICOzell a thicker insulation should be used or additional measures, such as an additional batten, should be used to reduce the possibilities of bellying. Any damaged boards edges should be suitably taped and sealed or the material should not be used.

- Cut edges, connections to other parts of the structure or penetrations should be structurally supported and carefully taped with an appropriate taping system. A minimum adhesive surface of 50mm is recommended on each board edge. When connecting to different materials, using circular penetrations or connecting in Eaves and Ridge then Butyl Tapes or collars should be used
- The boards can be temporarily nailed or stapled with the long term fix via an appropriate counter batten. Nail tight tapes beneath the batten is not required. Additional detail with regards to fixing is detailed in the tables on pages 6 – 9.

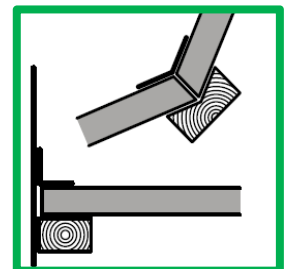

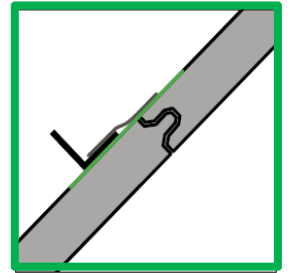
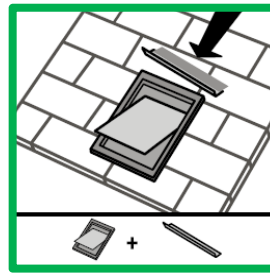
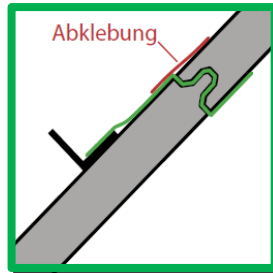
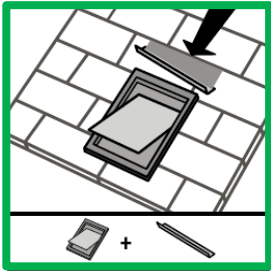

- Openings above the roof line, such as Roof Lights, should have an appropriate method of ensuring weathering protection. Roof lights built in during the construction phase should incorporate an external membrane built into the first horizontal board joint above the opening. This can then be used to attach an angle detail above the window and ensures a robust method of weathering protection.
- With roof lights that are fitted after the boards are laid the angle detail should be fitted above the opening and fixed via an appropriate taping system.

Fixing Method

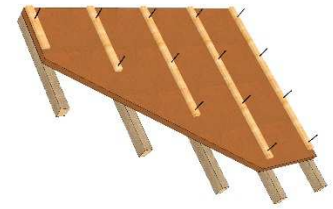

Allowable center spacings – Roof Applications

Thickness (mm)		max. center spacing (mm)	max. center spacing with air injected insulation (mm)
STEICO <i>universal</i>	22	750	625
STEICO <i>universal</i>	24	800	750
STEICO <i>universal</i>	35	1000	950
STEICO <i>universal</i>	52	1100	950
STEICO <i>universal</i>	60	1250	950
STEICO <i>special</i> / STEICO <i>universal dry</i>	60	1250	950
STEICO <i>special</i> / STEICO <i>universal dry</i>	80	1250	950
STEICO <i>special</i> / STEICO <i>universal dry</i>	100	1250	950
STEICO <i>special</i> / STEICO <i>special dry</i>	120	1250	950
STEICO <i>special dry</i>	140	1250	950
STEICO <i>special dry</i>	160	1250	950
STEICO <i>special dry</i>	180	1250	950
STEICO <i>special dry</i>	200	1250	950



Allowable center spacings – Wall Applications

Thickness (mm)		max. center spacing (mm)	max. center spacing with air injected insulation (mm)
STEICO <i>universal</i>	22	850	600
STEICO <i>universal</i>	24	900	700
STEICO <i>universal</i>	35	1000	850
STEICO <i>universal</i>	52	1100	850
STEICO <i>universal</i>	60	1250	850
STEICO <i>special</i> / STEICO <i>universal dry</i>	60	1250	850
STEICO <i>special</i> / STEICO <i>universal dry</i>	80	1250	850
STEICO <i>special</i> / STEICO <i>universal dry</i>	100	1250	850
STEICO <i>special</i> / STEICO <i>special dry</i>	120	1250	850
STEICO <i>special dry</i>	140	1250	850
STEICO <i>special dry</i>	160	1250	850
STEICO <i>special dry</i>	180	1250	850
STEICO <i>special dry</i>	200	1250	850

ROOF

The following fixing tables relate to calculations carried out by ITW 'Befestigungssysteme GmbH' and have been produced in line with the latest requirements of Eurocode 5 design.

They detail the center spacing of fixing for the counter batten based on the relevant worst case roof pitch with an allowance for Snow Load, Self-Weight of the structure and thickness of wood fibre material. Wind suction loads have been presumed at 1.1kN/m².

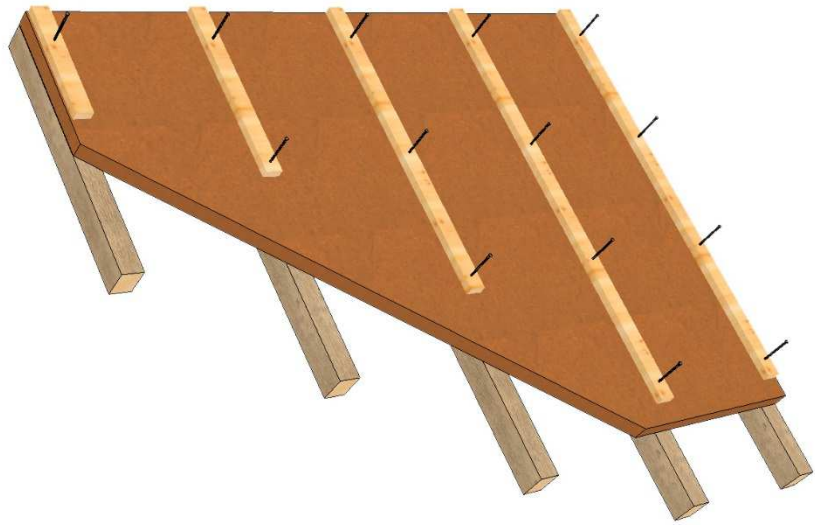

An independent structural analysis of appropriate fixings should be undertaken for all constructions which are outside of those detailed in the tables or if a different type of fixing is used. If using a 50/30 batten then a fixing suitable for wind loading should be used for the tile batten as the penetration depth of a plain round head nails is not achieved with 30mm. The tables show fixings for 750mm or 1000mm rafter center spacings. The maximum rafter spacing suitable for the insulation thickness given on page 6 should be considered.

STEICOuniversal / universal dry / special / special dry											
Thickness (mm) 22 / 24	Fixing by max. center spacing 750mm ¹⁾	Annular Ring Haubold 3.1*90					Staples Haubold SD 91090 / BS 29090				
		Pitch up to 35°			35°-55°		Pitch up to 35°			35°-55°	
Counter batten (w x h in mm) : 50 x 30		Snow Load kN/m ²					Snow Load kN/m ²				
		0.85	1.00	1.50	2.50	≤ 2.5	0.85	1.00	1.50	2.50	≤ 2.5
		Center spacing of fixing (mm)					Center spacing of fixing (mm)				
Lightweight Roofing	0.30 kN/m ²	200	200	200	150	200	150	150	150	100	150
Mediumweight Roofing	0.55 kN/m ²	200	200	150	100	200	150	150	150	100	150
Heavyweight Roofing	0.90 kN/m ²	150	150	150	100	100	150	150	100	100	100

STEICOuniversal / universal dry / special / special dry											
Thickness (mm) 35	Fixing by max. center spacing 1000mm ¹⁾	Annular Ring Haubold 3.8*130					Staples ³⁾ Haubold SD 91120 / BS 29120				
		Pitch up to 35°			35°-55°		Pitch up to 35°			35°-55°	
Counter batten (w x h in mm) : 60 x 40 ²⁾		Snow Load kN/m ²					Snow Load kN/m ²				
		0.85	1.00	1.50	2.50	≤ 2.5	0.85	1.00	1.50	2.50	≤ 2.5
		Center spacing of fixing (mm)					Center spacing of fixing (mm)				
Lightweight Roofing	0.30 kN/m ²	200	200	200	150	200	150	150	150	100	150
Mediumweight Roofing	0.55 kN/m ²	200	200	150	100	200	150	150	150	100	150
Heavyweight Roofing	0.90 kN/m ²	150	150	150	100	100	150	150	100	100	100

STEICO *universal / universal dry / special / special dry*

Thickness (mm) 52 - 60	Fixing by max. center spacing 1000mm ¹⁾	Annular Ring / Nail Screw Haubold 4.2*160 / 4.6*160					Nails ⁴⁾ 6*180				
		Pitch up to 35°			35°-55°		Pitch up to 35°			35°-55°	
Counter batten (w x h in mm) : 60 x 40 ²⁾		Snow Load kN/m ²					Snow Load kN/m ²				
		0.85	1.00	1.50	2.50	≤ 2.5	0.85	1.00	1.50	2.50	≤ 2.5
		Center spacing of fixing (mm)					Center spacing of fixing (mm)				
Lightweight Roofing	0.30 kN/m ²	200	200	200	150	200	120	120	120	100	60
Mediumweight Roofing	0.55 kN/m ²	200	200	200	100	100	120	120	120	50	60
Heavyweight Roofing	0.90 kN/m ²	200	200	150	100	100	120	120	100	50	60

¹⁾ without air injected insulation

²⁾ Counter batten with a 50 x 30 cross section can be used with 2.0*100 Staples

³⁾ Staples to be used when using STEICO *joist* as rafter construction

⁴⁾ When using counter batten 60 x 40 the 6.0*180 nails should be pre-drilled

A gap of at least 120mm should be left at the end of the counter batten before the first Nail or Screw and at least 70mm before the first staple. When using counter batten of a larger size the length of the fixing should be amended appropriately.

ROOFING

EXAMPLE MATERIALS

Lightweight Roofing	0.30 kN/m ²	Metal roofing incl timber cladding
Mediumweight Roofing	0.55 kN/m ²	Concrete tiles, Clay tiles
Heavyweight Roofing	0.90 kN/m ²	eg. Beavertail tiles Spanish curved tiles with mortaring

FIXINGS

ITW 'BEFESTIGUNGSSYSTEME GMBH'

Fixing	Length (mm)	Width (mm)	Shaft Diameter (mm)
Annular Ring.....3.1*90	90	-	3.1
Annular Ring.....3.8*130	130	-	3.8
Annular Ring.....4.2*160	160	-	4.2
Nail Screw.....3.8*130	130	-	3.8
Nail Screw.....4.6*160	160	-	4.6
Staple.....SD 91090	90	11.78	2.0
Staple.....BS 29090	90	27	2.0
Staple.....SD 91100	100	11.78	2.0
Staple.....BS 29100	100	27	2.0
Staple.....SD 91120	120	11.78	2.0
Staple.....BS 29120	120	27	2.0

Reference values for the fixing of STEICO insulation boards thicker than 60mm

The following tables should be used as a guide for structural applications but does not negate the need for full structural analysis. This structural analysis is the responsibility of the Project Engineer and should be carried out accordingly. They detail the center spacing of fixing for the counter batten based on a roof pitch of 30° with an allowance for Snow Load, Self-Weight of the structure and thickness of wood fibre material. Fixings that allow for Wind suction have not been considered and require additional analysis.

All selected fixings should be admissible for use in their intended area of application ie. attachment of an above rafter lying insulation. The corresponding fixing manufacturers are responsible for ensuring suitability. Depending on the selected fixing the center spacings of the fixings can be increased by 30% depending on head fixing and shaft diameter. The maximum center spacing for the rafter is 1250mm.

STEICO <i>special</i> / <i>special dry</i> / <i>universal dry</i>					
Thickness (mm)	Minimum screw size	max. center spacing (mm) Rafter spacing $e \leq 1000\text{mm}^{\text{b)}$		max. center spacing (mm) Rafter spacing $e \leq 850\text{mm}$	
60	8*180				
80	8*200				
100	8*220				
120	8*240				
140	8*260				
160	8*280				
Counter batten (w x h in mm) : 80 x 40		Snow Load kN/m²		Snow Load kN/m²	
		0.75	1.0	0.75	1.0
Mediumweight Roofing		0.60 kN/m ²		600	500
		700	600		

STEICO <i>special</i> / <i>special dry</i> / <i>universal dry</i>						
Thickness (mm)	Minimum screw size	max. center spacing (mm) Rafter spacing $e \leq 1000\text{mm}^{\text{b)}$			max. center spacing (mm) Rafter spacing $e \leq 850\text{mm}$	
60	6*180					
80	6*200					
100	6*220					
120	6*240					
140	6*260					
160	6*280					
Counter batten (w x h in mm) : 60 x 40		Snow Load kN/m²			Snow Load kN/m²	
		0.75	1.0	2.0	0.75	1.0
Mediumweight Roofing		0.60 kN/m ²			700	650
		550	500	400	550	550

A gap of at least 200mm should be left at the end of the counter batten before the first Screw. The effective screw spacing is determined by the counter batten length. As a rule the screws are fixed at a 67° angle to the rafter axis. The exact specifications should be obtained from the relevant approval of the manufacturer.

WALL

In areas of normal exposure the Shear forces and Suction forces are less for walls than they are for Roofs. This allows the above tables to be used when selecting appropriate spacings for fixings used in façade applications.

The fixings required in buildings with high façade loads (self weight of cladding systems, high wind loads) should be calculated on a job by job basis by the project Engineer.

Various fixing manufacturers such as HECO, FISCHER, Mungo or EJOTetc can offer a design service for these application areas.

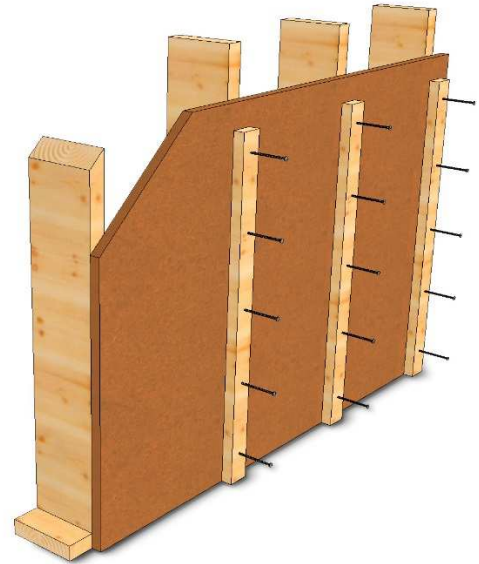

<http://www.heco-schrauben.de/de/Vertretungen/International>

<http://www.fischer.co.uk/Home.aspx>

<http://www.mungo.ch/en/>

<http://www.ejot.co.uk/>



Generic Details

D1 Eaves with low gutter

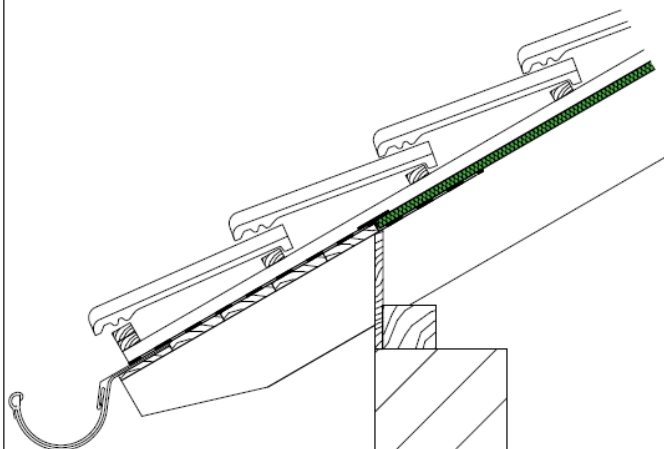

STEICO*universal* / STEICO*universal dry*

D2 Eaves with high gutter

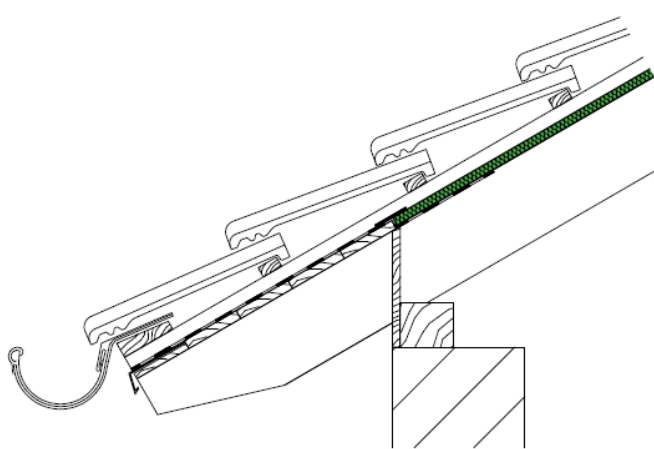

STEICO*universal* / STEICO*universal dry*

D3 Eaves with insulation above

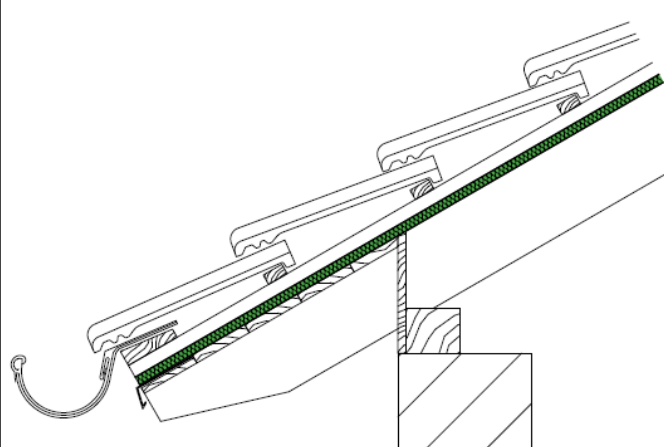

STEICO*universal* / STEICO*universal dry*

D4 Ventilated ridge

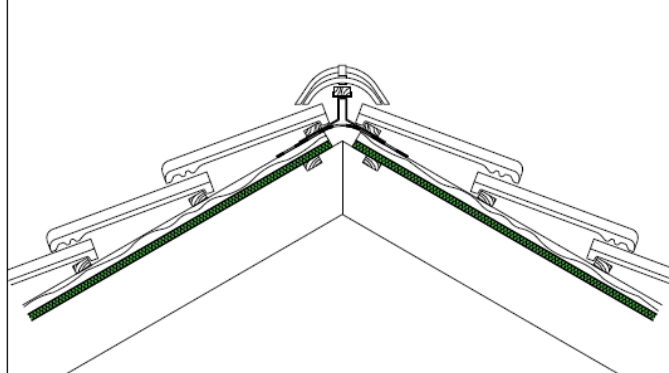

STEICO*universal* / STEICO*universal dry*

D5 Fully insulated ridge

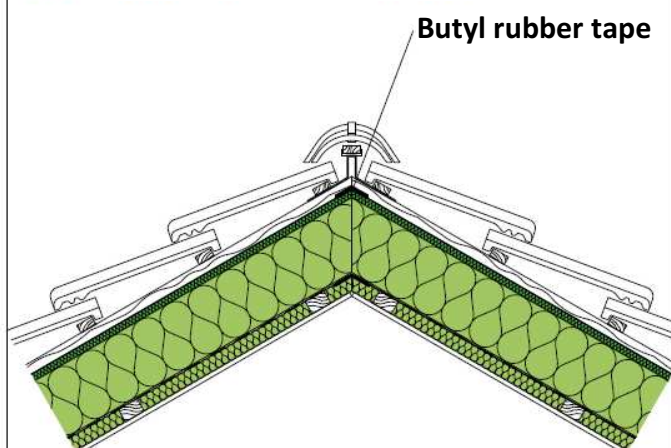

STEICO*universal* / STEICO*universal dry*

D6 Valleys

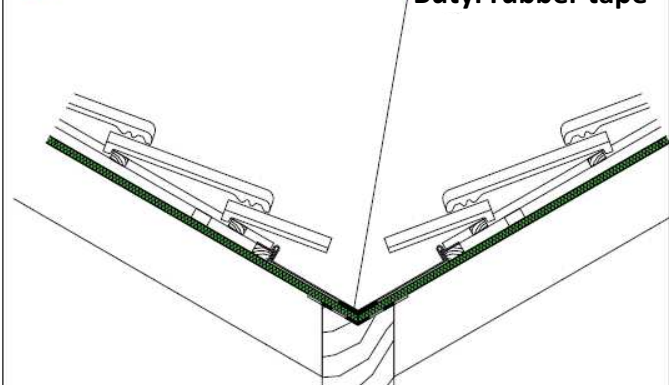

STEICO*universal* / STEICO*universal dry*

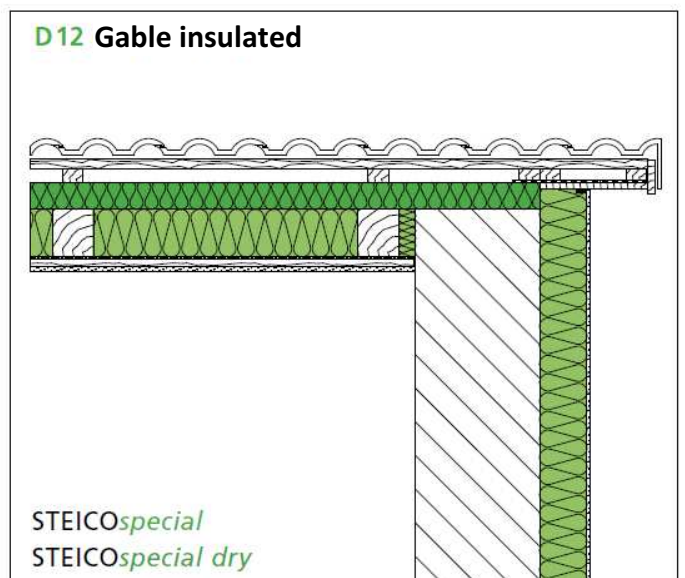
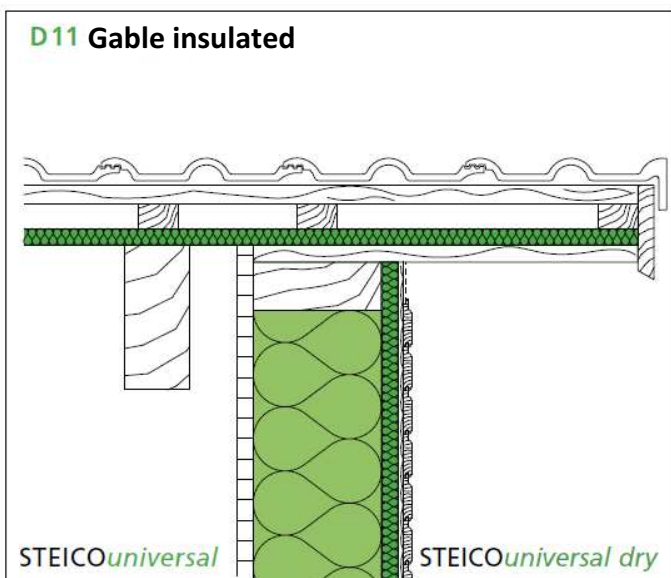
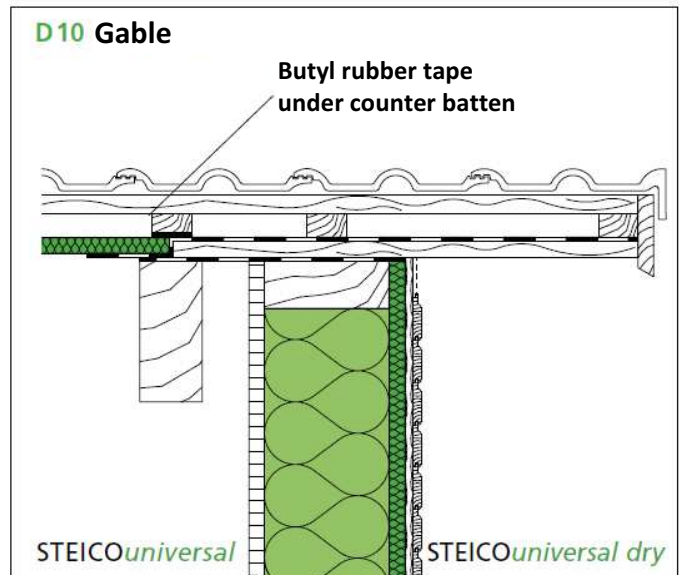
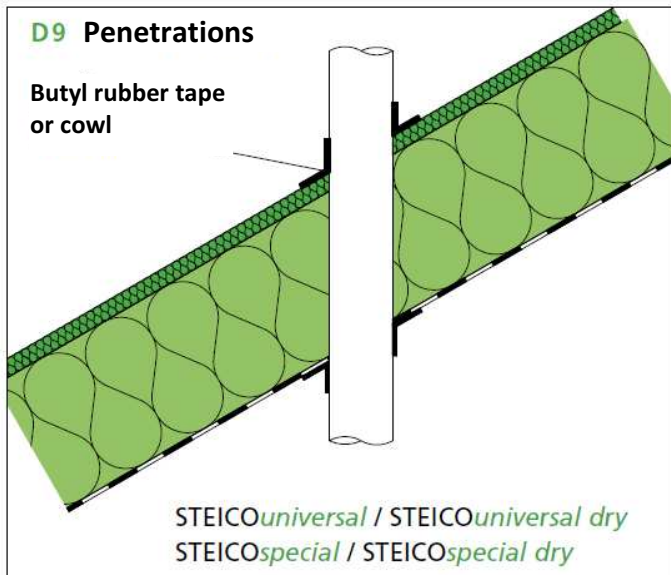
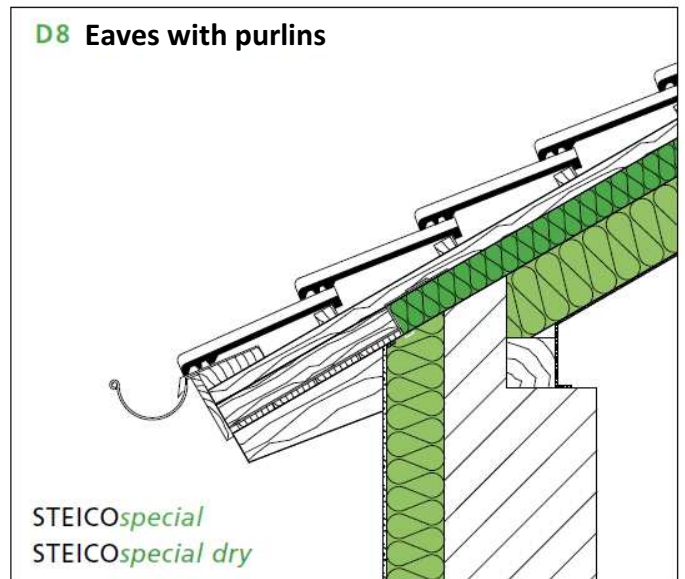
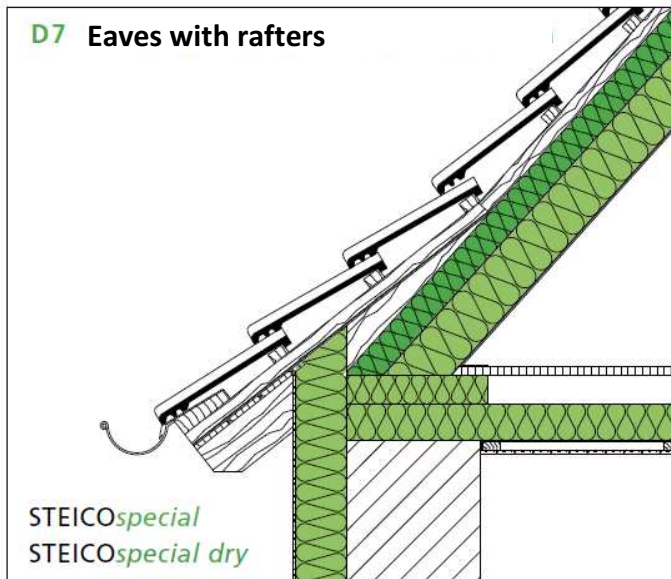

W1 DPC

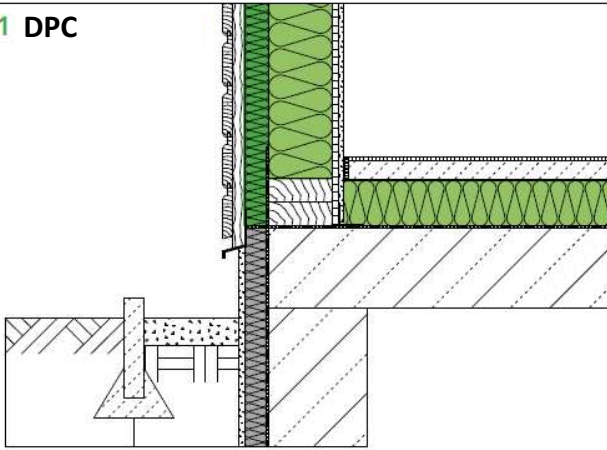

STEICOspecial
STEICOspecial dry

W2 External corner with STEICOjoist

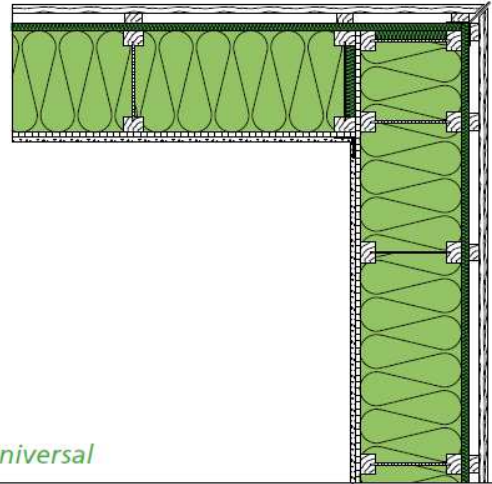

STEICOuniversal

W3 Window section

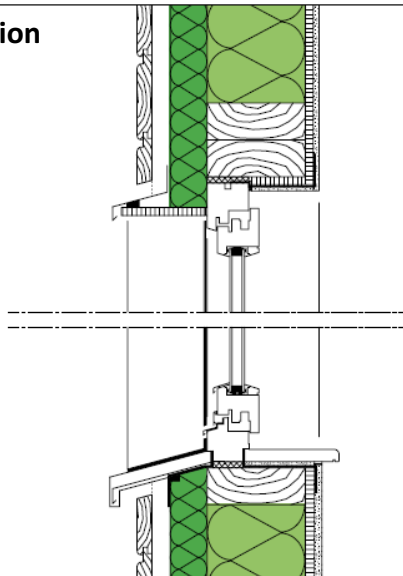

STEICOspecial
STEICOspecial dry

We spend approx. 80% of our lives in enclosed rooms. But are we always aware what we are surrounding ourselves with? STEICO has set itself the target of developing building products which consider the needs of both man and nature. Our products are therefore produced using sustainable natural materials. They help reduce energy use and add considerably to a natural healthy internal climate.



Steico insulation and construction materials, carry a number of distinguished 'seals of approval' which is a sign of high quality, healthy and functional building products. The raw materials used in Steico products are certified by FSC® (Forest Stewardship Council) and PEFC® (Programme for the Endorsement of Forest Certification), ensuring a traceable and fully sustainable usage of the raw materials. Steico, the number 1 choice for your sustainable building solutions.

Natural Insulation and Construction systems for new builds and renovations – Roof, Ceiling, Wall and Floor

	Renewable raw materials without harmful additives		Excellent heat insulation in winter		Excellent summer heat protection		Energy Saving and increased property worth
	Weather tight and breathable		Excellent Fire Protection		Excellent sound protection		Environmentally friendly and recyclable
	Light and easy to handle		Insulation for healthy living		Strong quality control		Compatible insulation and structural building systems



Sales and technical enquiries



tel: 01793 847 444
 email: info@ecomerchant.co.uk
 web: www.ecomerchant.co.uk